

NUTTALL OILFIELD STINGER

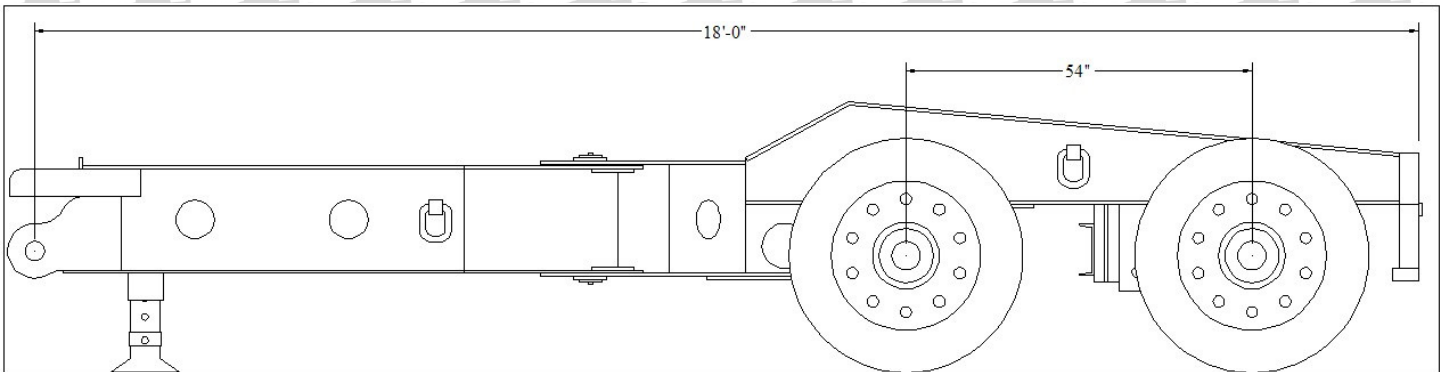

****SOME OPTIONS MAY BE SHOWN****

Standard Features:

- T1 Steel Beam Construction
- Amber Strobe Light Package
- Manual Override Air Ride Controls
- Your Choice of Standard Colors
- Exclusive Trailer Saver Crush Block System
- Dual Air-Lock Pins
- Tool Tray
- Flag Holders
- D-Rings

Additional Options Available:

- Custom Colors
- Aluminum Wheels
- Axle Spacing

Other options and axle configurations are available! Just give us a call and let us build the right trailer for your particular needs!



**FOR MORE INFORMATION CONTACT A DEALER NEAR YOU!
CALL 580-889-3351 TO FIND THE NEAREST DEALER**

C-ALL MFG., INC.
P.O. BOX 236
ATOKA, OK 74525

PHONE: 580-889-3351
FAX: 580-889-6173
WEB: www.nuttalltrailers.com
E-MAIL: sales@nutalltrailers.com